

IMPORTANT INFORMATION!

CAUTIONS for all Secador Auto-Desiccator cabinets:

- Do not place in front of a heating or air-conditioning duct
- Do not place near a heating device
- Do not place in direct sunlight
- Do not place in areas with smoke or steam
- Do not attempt to introduce pressure or vacuum inside the cabinet
- Do not place any explosive or hazardous chemicals in the cabinets
- Do not autoclave
- Indoor use only
- Use only within ambient temperature range of 5° C to 40°C

The user should be aware that if the equipment is used in a manner not specified by the manufacturer the protection provided by the equipment may be impaired. All of the Secador Desiccator Cabinets are molded in sections which are then sealed tight using silicon gaskets and unexposed steel bolts. This hardware is factory assembled and no attempt should be made to alter the tightness of the nuts.

*Digital Hygrometer Details

Please see the enclosed document titled "Scienceware Digital Hygrometer Specifications and Calibration Procedure" for all information regarding the digital hygrometer supplied with these desiccators.

ELECTRICAL RATING

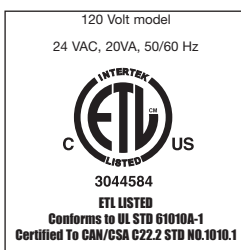

Bel-Art Products

WAYNE, NJ 07470-6814 USA

TEL: 1-800-4BEL-ART • FAX: 973-694-7199 • www.belart.com

© 2013 Bel-Art Products. All Rights Reserved. Scienceware® is a registered trademark of Bel-Art Products. Bel-Art Products assumes no obligation or liability for any advice furnished by it, or for results obtained with respect to these products. All such advice is given and accepted at the buyer's risk.

12/13



942070055

I N S T R U C T I O N S



Secador® Auto-Desiccator Cabinets with 120VAC Automatic Drying Module

General Secador Auto-Desiccator Information:

All Secador Desiccator Cabinets (except the Mini-Secador, Carrying Cases, and Refrigerator Ready Secador) are molded of a durable co-polyester resin in clear, blue or amber color, and that blocks over 99% of all harmful UV light. Doors feature a patented seal and are fitted with a precision digital hygrometer*. A loop on the door permits a padlock or a tamper evident tag to be used to prevent unauthorized opening. Each cabinet has a removable bottom shelf under which desiccant cartridges can be placed. Shelves are made of clear polystyrene, which are ribbed for strength and perforated for air exchange.

Vertical profile Secador Desiccator Cabinets have two door latches on the right side, and are interchangeably stackable up to three units high (4.0 units stackable to two high). Leave space in front for the door to swing open. Shelves must be angled 45 degrees to fit through the door opening, then leveled to rest upon the desired shelf rail. With all shelves in place and secure on the shelf rails, the distance between the shelves is 110mm (4 $\frac{3}{8}$ ") minimum.

Unlike acrylic desiccators, the co-polyester resin construction of the Secador Desiccator Cabinets can be cleaned (and disinfected) with ethanol, or similar laboratory detergents. Do not use abrasive cleansers as these may scratch the surface. We recommend the use of a clean, soft cloth and Bel-Art Products Aquet® Detergent, Catalog No. F17094-0030.

Bel-Art Products

WAYNE, NJ 07470-6814 USA

TEL: 1-800-4BEL-ART • FAX: 973-694-7199 • www.belart.com

SECADOR 2.0, 3.0, and 4.0 AUTO-DESICCATOR CABINET, VERTICAL PROFILE

Catalog No. F42072, F42073, F42074 Series

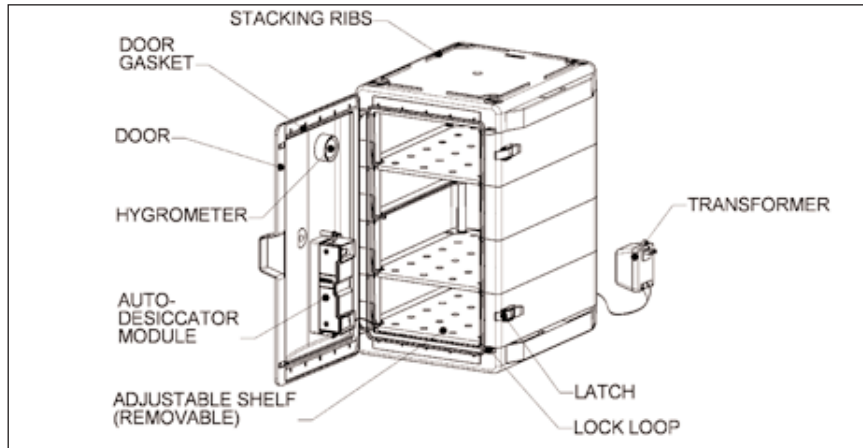

Installation of the Secador Auto-Desiccator is fast and simple. Begin by placing the desiccator on a flat horizontal surface, leaving room in front for the door to swing open. The door is fitted with the Secador Auto-Desiccator Module, which is housed in a polycarbonate case. The two apertures in the door exterior must be left unobstructed to permit proper venting of the Secador Auto-Desiccator Module. Next, you need to connect the electrical cord to the supplied transformer. Locate the transformer and remove it from its packaging. Locate the electrical cord extending from the desiccator. With the transformer UNPLUGGED from the power source, fully insert each of the two terminals, at the end of the electric cord, under each of the screw covers on the transformer (one terminal per screw cover). The Secador Auto-Desiccator Module is not polarized so either terminal can be attached to either screw. Fasten the terminals to the transformer by tightening the screws with a screwdriver. Plug the transformer into a properly functioning 120VAC electrical outlet. The internal green light inside the Secador Auto-Desiccator Module glows indicating the unit is in operation.

Once plugged in, the dehumidifying cycle will start immediately and the cabinet's moisture will be absorbed by the silica gel beads contained within the Secador Auto-Desiccator Module. This will be followed by a brief heating cycle within the electric unit and then by a discharge cycle when the moisture is released to the external atmosphere. Initially the cabinet should be left closed for approximately 8 hours to bring the relative humidity level to 25% rH or lower. The Secador Auto-Desiccator Module contains four air flow ports that are opened and shut by flapper valves. These valves were carefully aligned during factory installation to ensure proper function. DO NOT tamper with or pull on the valves.

SECADOR 4.0 AUTO-DESICCATOR CABINET, HORIZONTAL PROFILE

Catalog No. F42074-0100, F42074-0115

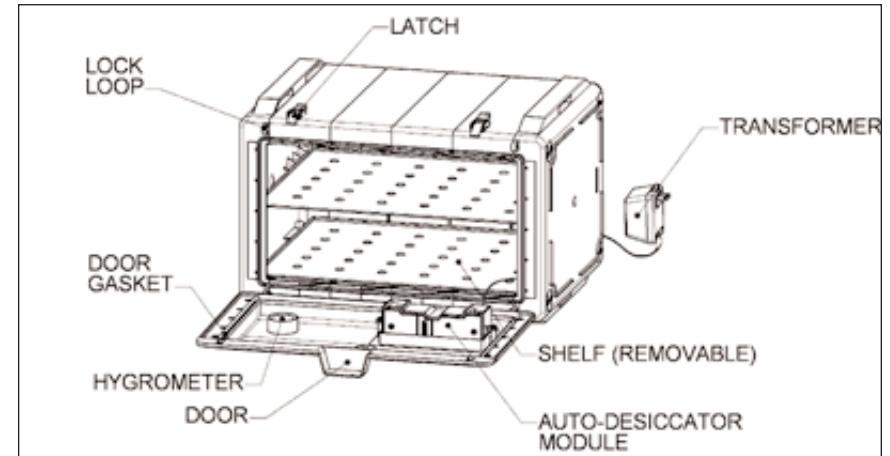

Installation of the Horizontal Secador Auto-Desiccator is fast and simple. Begin by placing the desiccator on a flat horizontal surface, leaving room in front for the door to swing open. The cabinet should be placed such that the two door latches are at the top. The door is fitted with the Secador Auto-Desiccator Module, which is housed in a polycarbonate case. The two apertures in the door exterior must be left unobstructed to permit proper venting of the Secador Auto-Desiccator Module. Next, you need to connect the electrical cord to the supplied transformer. Locate the transformer and remove it from its packaging. Locate the electrical cord extending from the desiccator. With the transformer UNPLUGGED from the power source, fully insert each of the two terminals, at the end of the electric cord, under each of the screw covers on the transformer (one terminal per screw cover). The Secador Auto-Desiccator Module is not polarized so either terminal can be attached to either screw. Fasten the terminals to the transformer by tightening the screws with a screwdriver. Plug the transformer into a properly functioning 120VAC electrical outlet. The internal green light inside the Secador Auto-Desiccator Module glows indicating the unit is in operation.

Once plugged in, the dehumidifying cycle will start immediately and the cabinet's moisture will be absorbed by the silica gel beads contained within the Secador Auto-Desiccator Module. This will be followed by a brief heating cycle within the electric unit and then by a discharge cycle when the moisture is released to the external atmosphere. Initially the cabinet should be left closed for approximately 8 hours to bring the relative humidity level to 25% rH or lower. The Secador Auto-Desiccator Module contains four air flow ports that are opened and shut by flapper valves. These valves were carefully aligned during factory installation to ensure proper function. DO NOT tamper with or pull on the valves.

Secador® Auto-Desiccator Cabinet Replacement Desiccant Catalog No.42074-0020

1. Disconnect the electronic desiccating unit located on the door of the Secador® Desiccator cabinet by pulling out the electrical connector on the lower edge.
2. Release the electronic desiccating unit from the door by unscrewing the two holding screws on the ends a few turns. Do not remove the screws.
3. Do not touch the four window flaps or metal retainers of the unit. Remove the unit and place it on the lab bench with the soft plastic plug upward.
4. Remove the plastic plug and discard.
5. Pour the used desiccant out of the unit without disturbing the flaps or metal retainers.
6. Remove the cap from bottle containing new desiccant and insert the neck of the bottle into the well from which the soft plastic plug was removed. Pour the entire contents of the bottle into the unit.
7. Insert the new replacement plastic plug into the filler hole, being sure that it is completely inserted.
8. Attach the electronic desiccating unit to the Secador® cabinet door. Be sure that the washers are directly under the screw heads. Do not overtighten the screws.
9. Reconnect the electrical connector inside the cabinet to the electronic desiccating unit.

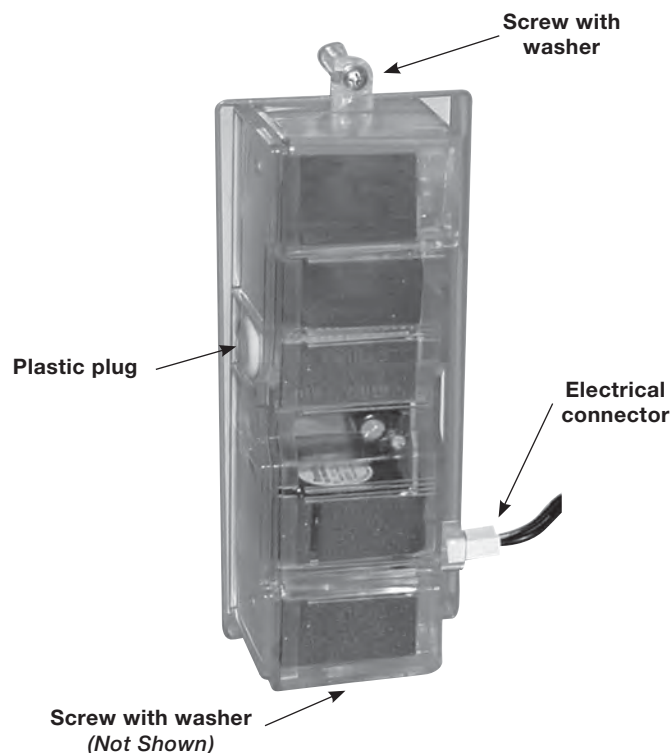

I N S T R U C T I O N S



Secador® Auto-Desiccator Cabinets with 230VAC Automatic Drying Module

General Secador Auto-Desiccator Information:

All Secador Desiccator Cabinets are molded of a durable co-polyester resin in clear, blue or amber color, and that blocks over 99% of all harmful UV light. Doors feature a patented seal and are fitted with a precision digital hygrometer*. A loop on the door permits a padlock or a tamper evident tag to be used to prevent unauthorized opening. Each cabinet has a removable bottom shelf under which desiccant cartridges can be placed. Shelves are made of clear polystyrene, which are ribbed for strength and perforated for air exchange.

Vertical profile Secador Desiccator Cabinets have two door latches on the right side, and are interchangeably stackable up to two units high. Leave space in front for the door to swing open. Shelves must be angled 45 degrees to fit through the door opening, then leveled to rest upon the desired shelf rail. With all shelves in place and secure on the shelf rails, the distance between the shelves is 110mm (4 $\frac{3}{8}$ ") minimum.

Unlike acrylic desiccators, the co-polyester resin construction of the Secador Desiccator Cabinets can be cleaned (and disinfected) with ethanol, or similar laboratory detergents. Do not use abrasive cleansers as these may scratch the surface. We recommend the use of a clean, soft cloth and Bel-Art – SP Scienceware Aquet® Detergent, Catalog No. F17094-0030.

661 Route 23 South, Wayne, NJ 07470

TEL: 973-694-0500 • FAX: 973-694-7199 • www.belart.com

Bel-Art – SP Scienceware assumes no obligation or liability for any advice furnished by it, or for results obtained with respect to these products.

All such advice is given and accepted at the buyer's risk.

© 2017. All Rights Reserved.

Bel-Art® – SP Scienceware® is a division of SP Industries, Inc.



942070106 – 08/17



SECADOR® 2.0, 3.0, and 4.0

AUTO-DESICCATOR CABINET, VERTICAL PROFILE

Catalog No. F42072-1220, F42072-1228, F42073-1220, F42073-1228,
F42074-1220, F42074-1226, F42074-1227, F42074-1228

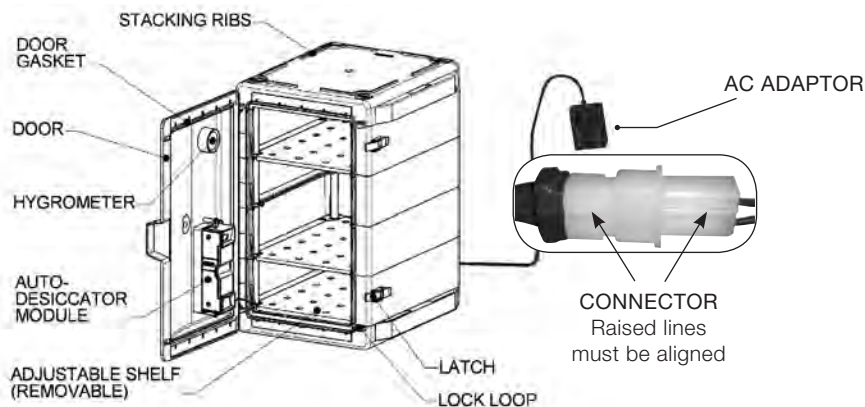

SECADOR™ 4.0 AUTO-DESICCATOR CABINET, HORIZONTAL PROFILE

Catalog No. F42074-0220, F42074-0226, F42074-0227

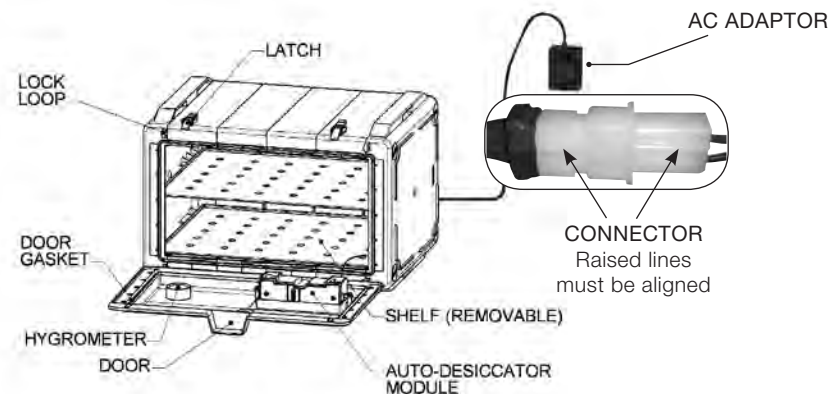

The cabinet should be placed on a horizontal surface leaving room in front for the door to swing open. The door is fitted with an electronic dryer housed in a polycarbonate case. The two apertures in the door must be left unobstructed. Remove the Secador® AC adaptor from the package. With the AC adaptor UNPLUGGED from the power source, join the white plastic connector on the end of the cable from the AC adaptor with the similar plastic connector on the end of the cable from the back side of desiccator cabinet. Ensure that the raised lines on the connectors are aligned. See picture. Plug the AC adaptor into the proper electrical outlet. The internal green light in the auto-desiccator module glows when the unit is in operation. The dehumidifying cycle will start immediately causing the

cabinet's moisture to be absorbed inside the door's electronic dryer. This will be followed by a brief heating cycle within the electric unit and then by a discharge cycle when the moisture is released to the external atmosphere. Initially the cabinet should be left closed for approximately 8 hours to bring the relative humidity reading down into the 25% range. The electrical unit contains four air flow ports that are opened and shut by flapper valves. These valves were carefully aligned during factory installation to ensure proper function. DO NOT tamper with or pull on the valves.

Polystyrene ribbed shelves are provided. Each is perforated for air movement. The minimum distance between shelves is 95mm (3.75"). When filling the cabinet, try to leave the door open a minimum of time.

The cabinet should be placed on a horizontal surface with the two door latches at the top. The door is fitted with an electronic dryer housed in a polycarbonate case. The two apertures in the door must be left unobstructed. Remove the Secador® AC adaptor from the package. With the AC adaptor UNPLUGGED from the power source, join the white plastic connector on the end of the cable from the AC adaptor with the similar plastic connector on the end of the cable from the back side of desiccator cabinet. Ensure that the raised lines on the connectors are aligned. See picture. Plug the AC adaptor into the proper electrical outlet. The internal green light in the auto-desiccator module glows when the unit is in operation.

The dehumidifying cycle will start immediately causing the cabinet's moisture to be absorbed

inside the door's electronic dryer. This will be followed by a brief heating cycle within the electric unit and then by a discharge cycle when the moisture is released to the external atmosphere. Initially the cabinet should be left closed for approximately 8 hours to bring the relative humidity reading down into the 25% range. The electrical unit contains four air flow ports that are opened and shut by flapper valves. These valves were carefully aligned during factory installation to ensure proper function. DO NOT tamper with or pull on the valves.

Two removable polystyrene ribbed shelves are provided. Each is perforated for air movement. With all shelves in place, the distance between shelves is 111 mm (4.375") minimum. When filling the cabinet, try to keep the door open a minimum of time.

IMPORTANT INFORMATION

- Be sure to position the unit to permit unobstructed access to disconnect AC adaptor from the outlet.
- Maximum loading capacity is 2.0lb/shelf.
- Use only the AC adaptor supplied with the unit.
- Do not place in front of a heating/ac duct.
- Do not place near a heating device.
- Do not place in direct sunlight.
- Do not place in areas with smoke, or steam.
- Do not attempt to introduce pressure or vacuum inside the cabinet.

- Do not place any explosive or hazardous chemicals in the cabinets.
- Do not autoclave.
- Indoor use only.
- Use only with ambient temperature range of 5°C to 40°C.
- Do not lift or carry unit without completely emptying out the cabinet and disconnecting the power by unplugging AC adaptor from the wall outlet.
- Unit must be connected to the wall outlet with over current protection

IMPORTANT INFORMATION

The user should be aware that if the equipment is used in a manner not specified by the manufacturer the protection provided by the equipment may be impaired. All of the Secador Desiccator Cabinets are molded in sections which are sealed tight by unexposed steel bolts. This hardware is factory assembled and no attempt should be made to alter the tightness of the nuts.

*Digital Hygrometer Details

Please see the enclosed document titled "Scienceware Digital Hygrometer Specifications and Calibration Procedure" for all information regarding the digital hygrometer supplied with these desiccators.

ELECTRICAL RATING

- 230 volt Model • 24 volts • 24 watts • 50-60Hz



IMPORTANT INFORMATION